

SURGE PROTECTIVE DEVICE



Surge Protective Device

Specifications

SPD (Surge Protective Device) is also known as TVSS (Transient Voltage Surge Suppressors.) Shihlin products meet the IEC 61643-11, IEC 61312 standard of International Electrotechnical Commission, and follow the standard IEC 61000-5-6, VDE 0675, NFC 61740, UL 1449-2, UL 1283, CSA 22.2, GB 18802-1, ANSI C62.41, IEEE C62.41 and NFPA-70.

Electrical Characteristics

- A. SPD structure: Inner core part is a metal oxide varistor made with zinc oxide.
- B. Rated voltage (Un): The rated voltage of SPD device will be the same with rated voltage of the device being protected.
- C. Maximum continuous operating voltage (Uc): 155VAC, 275VAC (common), 385VAC, 440VAC (590VDC); Uc should be 15% greater than Un.
- D. Frequency: 48-60 Hz (also suited for DC.)
- E. Time: 10~100ns.
- F. Voltage protection level (Up): Less than rated impulse withstand voltage of the device being protected.
- G. Life expectancy: It takes voltage surge 10000 times within rated discharge current (3kA.)
- H. Impulse withstand voltage: 20kV (1.2/50 μ s)
- I. Operating temperature: -5°C+40°C, relative humidity: 30~99%, operating altitude: 2000 meter below.
- J. Provide parallel protection: L-N, L-G (L-E), N-G (N-E)
- K. The test is done by applying 10 cycles of 1420 voltage and 300 ampere on to both side of the device. Testing result is good that the device is not on fire.
(IEC requirement: SPD is allowed to caught on fire but cannot ignite surrounding object)

Features

- A. Modular design, anti-error assembling design, withdraw able surge arrestor allow quick replacement of the failed module (end of life) without cutting the power.
- B. With standard DIN rail (35mm) installation, easy to install and speed up the replacing process.
- C. The IP code dustproof and waterproof level is IP20.
- D. Meets the IEC 61643-11 standard and CE declaration.
- E. Voltage impulse counter (AC110V/220V) is available for monitoring maximum of 99 counts.
(Has memory function, non-return to zero after power failure.)

Operating Principle

- A. Voltage limiting type SPD: Having high impedance when no surges occur and as the surge voltage and current increase, the impedance decrease. By using varistor and transient voltage suppressor (TVS). Leakage current is limited, with fast response time and low residual voltage.
- B. Voltage switching type SPD: Having high impedance when no surges occur and become low impedance when surges occur. Use discharge gap and gas discharge tube type parts. Voltage discharge capability is high.
- C. Combination type SPD: A combination of voltage limiting type SPD and voltage switching type SPD. Having fast response time characteristic of voltage limiting type SPD and strong discharge capability characteristic of voltage switching type SPD.

Mechanical Auxiliary Contacts

Each device comes with auxiliary contacts for alarm device system to display malfunction.

BHP20 ∙ 40 : 1NO ∙ 1NC

BHP80 ∙ 100 : 1NO

Type Designation

BHP	20	—	3P	R	320
Type	Max. discharge current I _{max} /I _{imp} (kA)		Number of poles (P)	Alarm auxiliary contact R: with Blank: without	Max. continuous operating voltage U _c (V)
					Standard operation voltage
BHP	20	20kA (8/20μs)	1P: 1P	R	275V 320V
	40	40kA (8/20μs)	1P1: 1P+1 2P: 2P	R	275V 385V
	80	80kA (8/20μs)	3P: 3P 3P1: 3P+1	R	275V 385V
	100	100kA (8/20μs)	4P: 4P	R	275V 385V
	250	25kA (10/350μs)			275V 440V

In order to use surge protective device more effectively, the following information is necessary.

1. The grounding system types of the protected device and the maximum operating voltage of the power grid U_s. Max.
2. The impulse withstand voltage of the protected device.

<ul style="list-style-type: none"> • Common mode Protection of line to earth (Protection of line and neutral to earth) • Differential mode Protection of line to earth and neutral(Protection of line to neutral and line to earth) 	Max. continuous operating voltage U _c (V)	Protective mode	TT	TT	TN-S	TN-C	IT	IT
	Grounding system		Before RCD	After RCD			Neutral point earthing	Neutral point non-earthing
	275V 320V	Common	—	—	2P	2P	—	3P
		Differential	—	—	1P+1	1P+1	1P+1	—
	385V 440V	Common	3P	4P	4P	4P	—	3P
Differential		3P+1	—	—	—	3P+1	—	

Operating Conditions

- **Frequency:** 48~60Hz.
- **Voltage:** The voltage continuously applied on between the wiring terminal of the surge protective device shall not exceed its maximum continuous operating voltage U_c.
- **Altitude:** Less than 2,000M.
- **Temperature:** - Normal range: -5°C ~ +40°C;
- Ultimate range: -40°C ~ +70°C;
- **Humidity- Relative humidity:** 30%~90%, non-condensing.

Combination Selection of Surge Protective Device and Circuit Breaker

The internal core of SPD is one zinc-oxide pressure-sensitive element and zinc oxide consists of crystal. When a surge current far beyond the upper-limit value flow through the SPD, certain crystal boundary in the ceramic will be damage. Under extreme circumstances, excessive heat generated by continuous overloading will damage the crystal, and even break the crystal down under serious conditions, leading to the fusion of ZnO crystal and thus causing short circuit. A ware of intense heat gives no time to transmit the heat to the thermal fuse, therefore, a fuse or circuit breaker must be used for cutting off the power.

Even under the condition of precise parameter selection, the extreme temperature rise and burst of the SPD due to overloading are not avoidable.

SPD		Circuit Breaker		
Max. discharge current I_{max}/I_{imp} (kA)		Rated current	Trip characteristic	Model
20kA (8/20 μ s)		32A	C	BHA2XC32
40kA (8/20 μ s)		50A	C	BHA2XC50
80kA (8/20 μ s)		63A	C	BHA3XC63
100kA (8/20 μ s)		100A	10In \pm 20%	BHA100XP100A
25kA (10/350 μ s)		100A	10In \pm 20%	BHA100XP100A

- Notes:**
- The X in the breaker model indicates the pole number, for example, to design a breaker for BHP40, in combination with 4-pole 25A breaker, the model shall be BHA24C25.
 - The breaking capacity of the breaker must be larger than the maximum short circuit at the same position.
 - Protection shall be provided for each pole of the surge protective device.
 - For PT secondary circuit protection, due to the restriction of the maximum load current of PT, full consideration shall be given to the following circumstance:
 - The maximum short circuit current of PT, it is noted that, when discharge with excessive energy gets SPD breakdown and short-circuit, the secondary circuit shall not have voltage break down. At this moment, the release current and quick response capacity of the breaker must be considered.
 - No-fuse circuit breaker may be considered, since standard no-fuse circuit breaker cannot be melted down by the pulse current. On the contrary, the breaker can protect SPD from freewheeling, and damages caused by the continuous surge.

Parameter of Surge Protective Devices

Model	U_n (V)	U_c -AC (V)	U_c -DC (V)	U_p (kV)	I_n (kA)	I_{max} (kA) (8/20 μ s) Class II	I_{imp} (kA) (10/350 μ s) Class I	Type	Connection	
									L-N	PE
BHP20	230/ 400	275	350	1.1	10	20	-	Cassette	$\geq 2.5\text{mm}^2$	$\geq 6\text{mm}^2$
		320	410	1.2	10	20	-		$\geq 4\text{mm}^2$	$\geq 16\text{mm}^2$
BHP40	230/ 400	275	350	1.3	20	40	-		$\geq 10\text{mm}^2$	$\geq 25\text{mm}^2$
		385	500	1.8	20	40	-		$\geq 16\text{mm}^2$	$\geq 25\text{mm}^2$
BHP80	230/ 400	275	350	1.8	40	80	-	Fixed	$\geq 25\text{mm}^2$	$\geq 35\text{mm}^2$
		385	500	2.1	40	80	-		$\geq 25\text{mm}^2$	$\geq 35\text{mm}^2$
BHP100	230/ 400	275	350	2.1	60	100	-		$\geq 25\text{mm}^2$	$\geq 35\text{mm}^2$
		385	500	2.3	60	100	-		$\geq 25\text{mm}^2$	$\geq 35\text{mm}^2$
BHP250	230/ 400	275	-	2.3	-	-	25	$\geq 25\text{mm}^2$	$\geq 35\text{mm}^2$	
		440	-	2.3	-	-	25	$\geq 25\text{mm}^2$	$\geq 35\text{mm}^2$	

Wiring Diagrams

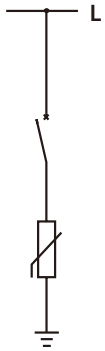

1P

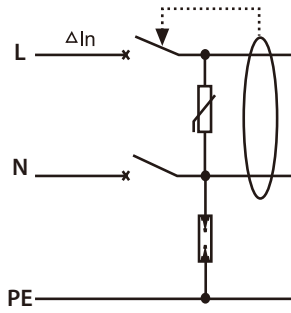

1P+1

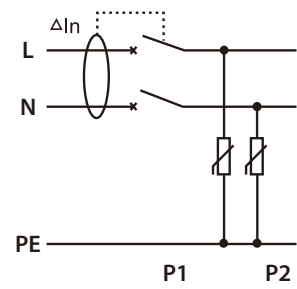

2P (1P+N)

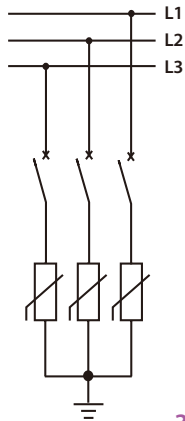

3P

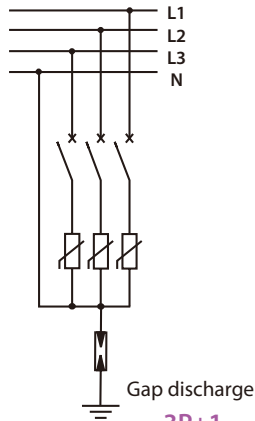

3P+1

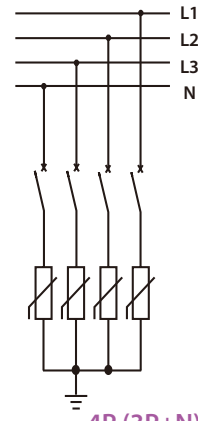

4P (3P+N)

Dimensions (mm)

BHP20/40

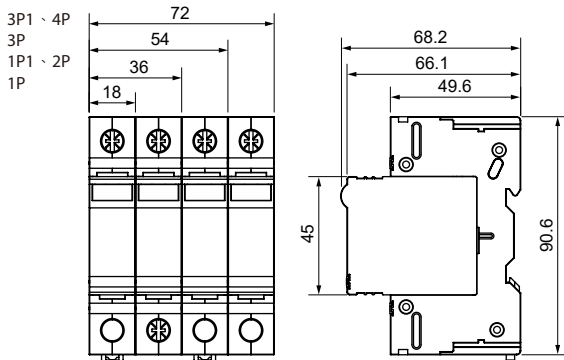

BHP80/100

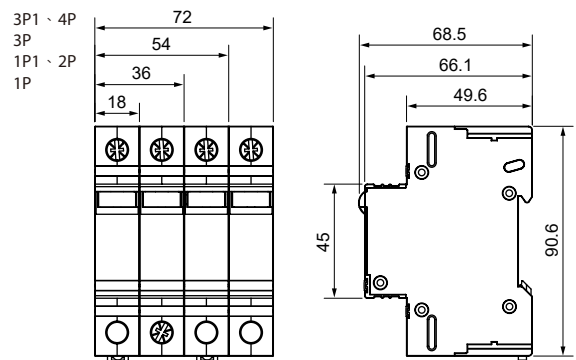

BHP250

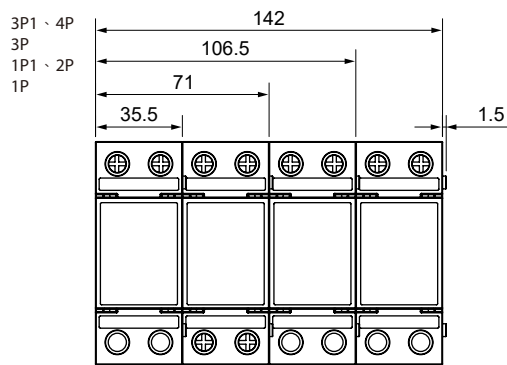

Installation Method of SPD

1. The cable for connecting SPD shall be as short as possible, since the impedance of the wire will weaken the protection capability of SPD.
2. To ensure effective protection, it is suggested to install one lead-in device to split the current at the incoming side of the device.
3. When a switching device and a SPD are mounted in a serial manner, the wire shall be as short as possible.

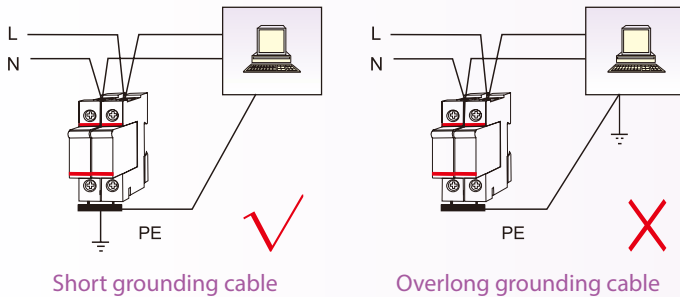

The cassette module of BHP series surge protective device, there is unique guiding hole at the bottom of the base; cassette module with different specifications cannot be plugged in if interchanging positions. The core side is using high-grade insulation material; therefore, when pulling out the cassette module, its live parts cannot be touched.

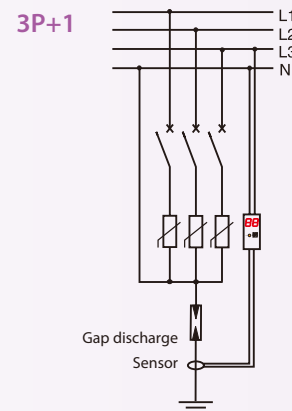
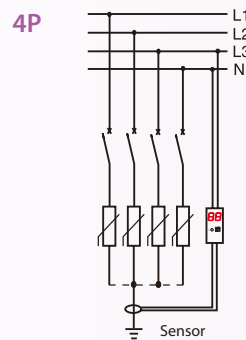

Counter

Type	TAD-04-99
Rated operation voltage	AC 85~250V
Counter pulse threshold	$\geq 1\text{kA}$
Maximum count	99
Counting method	Pulse
Counter display method	2 digits LED red
Minimum interval between counter pulses	$\geq 200\text{ms}$
Digital memory method	Pulse falling edge, flash accumulation record
Dimension	91×68×18 (mm)

Note: Lightning strike pulse counter can count the discharge pulses and store them to the single-chip FLASH, and features intuitive display and small volume.

BHD SURGE PROTECTIVE DEVICE BACKUP PROTECTION

BHD Series | 65kA/100kA

Overview :

The BHD Series SPD Disconnecter is designed to isolate the SPD from the system during SPD failure and maintenance. It features a trip function to detect and disconnect leakage current caused by SPD deterioration (e.g., varistor burnout). With high surge resistance, BHD helps prevent nuisance tripping during normal surge discharge.

Product Features :

- Safe SPD Isolation
Separates the SPD from the system for failure conditions and maintenance operations.
- Leakage Current Disconnection
Trips on leakage current caused by SPD aging/deterioration to reduce secondary risk.
- High Surge Withstand
High surge resistance to minimize unintended operation during normal surge discharge.

Type designation :

BHD	20	R	1
↓	↓	↓	↓
Type	Maximum Discharge Current I _{max} (kA)	Rated Short-Circuit Breaking Capacity I _{cs} (kA):	Pole(P)
BHD	20: 20kA (8/20 μs) 40: 40kA (8/20 μs) 80: 80kA (8/20 μs) 120: 120kA (8/20 μs) 250: 250kA (10/350 μs)	R: 65kA U: 100kA	1: 1P 2: 2P 3: 3P 4: 4P

Technical Specifications :

Type	BHD20R	BHD20U	BHD40R	BHD40U	BHD80R	BHD80U	BHD80U	BHD120R	BHD120U	BHD250R	BHD250U
Rated Current I _n (A)	10	10	20	20	40	40	40	60	60	80	80
Rated Operating Voltage U _e	AC 230/240 V (1P/2P), AC 230/400 V (3P/4P)										
Maximum Impulse Current I _{imp} (kA)	-	-	-	-	-	-	-	-	-	25	25
Maximum Discharge Current I _{max} (kA)	20	20	40	40	80	80	80	120	120	-	-
Rated Short-Circuit Breaking Capacity I _{cn} (kA)	65	100	65	100	65	100	100	65	100	65	100
Number of Poles	1P, 2P, 3P, 4P										
Minimum Time-Delay Tripping Current I _d	3 A ± 1 A										
Minimum Instantaneous Tripping Current I _i	5A										

Operating Conditions :

- Ambient Temperature: -25°C to +60°C
- Altitude: ≤ 2000 m
- Relative Humidity: 20% to 90%
- Pollution Degree: Class 3
- Vibration: Sinusoidal vibration (10 Hz to 50 Hz, amplitude 1.5 mm)

BHD120/250

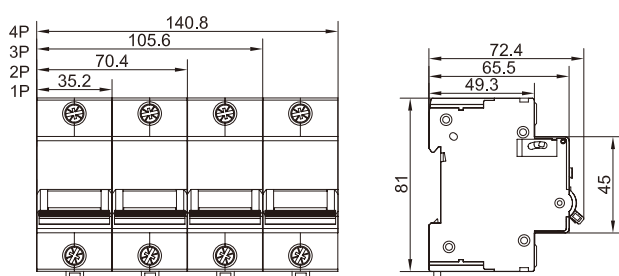

BHD20/40/80

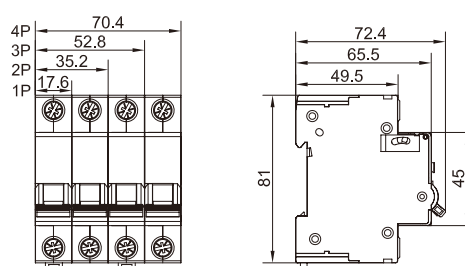

Selection Guide

1. The selection of SPD has nothing to do with transformer capacity or breaker's breaking capacity, it is based on the device being protected and the installation location. Such as open place, downtown area, suburbs area and thunder lighting frequency. BHP40 is recommended to be used in a normal application and increase or decreases the rating depend on how the environment is. Select the numbers of poles depend on the number of poles of the device being protected. There are chances that neutral pole will be damaged by lightning and need protection as well. For example: power source with 3 phase 4 wires device, you should use 3P+N (4P) or 3P+1 (3P1MOV+ GDT). This 3 phase compound modularize device has good insulating for protection, which cassette module can be changed without cutting power.
2. When installing SPD in different positions, we recommend that the wire distance between 2 SPD should not be less than 5m; otherwise, the added SPD doesn't provide additional protection. If the distance between SPD and the protected equipment is greater than 30m, the surge will be amplified, which may cause the open end of the equipment over-voltage. As the result, a SPD is recommended to be added, that is, the distance between 2 SPD should be greater than 5m and less than 30m.
3. According to SPD testing requirements in UL 1449, a 100kA MCCB must be added in front of the SPD when the SPD is wired in series with a 100kA power system. If the SPD is wired in parallel with the power system, adding a MCCB is only for further protection. The purpose of MCCB is to disconnect the power when SPD is short circuit caused by transient overvoltage. The rating of MCCB is depend on earthing method and the distance between SPD and transformer, in which position the maximum short circuit current may occur. The breaking capacity of MCCB is decided by transformer rating, it is not related to the kA value of the SPD.
4. SPD selection:
 - A. Make sure the surge was caused by lightning or operating overvoltage.
 - B. Verify the Lightning Protection Zones (LPZ0, LPZ1, LPZ2, and LPZ3).
 - C. Surge protecting mode is different depend on earthing method.
 - D. Verify the surge withstand capability of the protected device (U_{imp}) (kV).
 - E. Surge protection should be class II.
 - F. Add MCCB or HRC fuse for backup protection.
 - G. Keep the earthing wire as straight as possible because bending the wire will increase the earthing impedance and affect the discharge of surge current.
 - H. Use standard wire to avoid skin effect.
 - I. The wire for earthing should be as short as possible (less than 0.5M) and wire diameter as big as possible.
 - J. Tie up the parallel earthing wire to separate with the other conductive parts.
5. Wiring method between continuation of power supply and equipment protection:
 - A. Ensure continuation of power supply: Add an overcurrent protection device in the SPD circuit to ensure continuous power supply when the SPD is damaged. But when another surge occurs, both electrical device and equipment will not get any protection.
 - B. Ensure equipment protection: if the overcurrent protection device is added right up-stream of the protected SPD and equipment, the power will be cut off if SPD is damaged, but the equipment protection is guaranteed.
 - C. Ensure continuous power supply and equipment protection: Using two SPD wiring in parallel to ensure continuous power supply and protecting the equipment at the same time. When one SPD is damaged, the other SPD will not be affected and continue protecting the equipment. (Picture 3)
6. There are 4 lightning protection levels (IEC 61312-1 standard): Type 1 protects electrical installations against direct lightning strikes (protection level A) and is characterized by 10/350 μ s current wave; type 2 prevents the spread of over voltages in the electrical installations (protection level B, C, D) and is characterized by 8/20 μ s current wave.
7. The MOV surge protection devices' response time is between 10~100 ns or within 25ns. Device somewhere in the market marked "response time within 1ns" should not be using MOV for protection.
8. The requirement and label marked value present difference; user must pay attention and clarify for selection. For example: Peak Pulse Power Dissipation (Ppp) is usually between 150 watt to 90,000 watt, or presented in the manner of Joules. This value is removed in UL 1449 standard due to the difficulty of the calculation of the value and replaced with Short Circuit Current Rating (kA).
9. Lightning surge is discharge by earthing, as the result, the wiring for SPD is L-PE and N-PE. Transformer's neutral line is connected with PR line, wiring method L-N, N-PE must be used in the way of combination. L-L method is rarely used.

SPD Wiring Example

TN-C system three phase

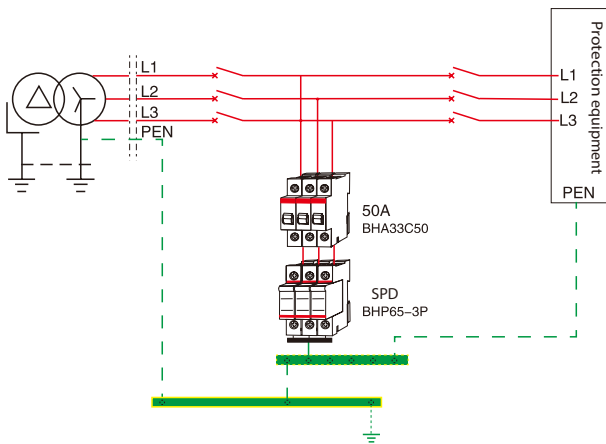

TN-S system three phase

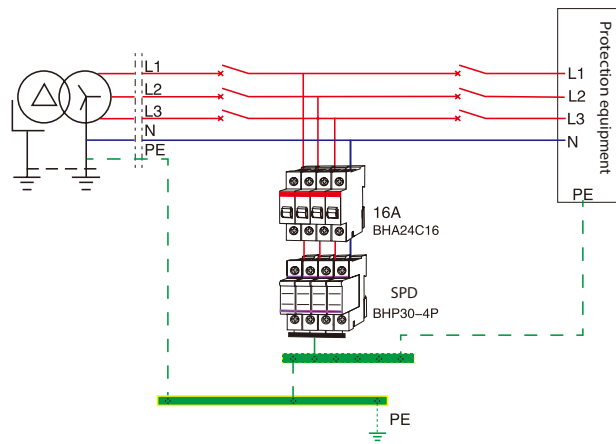

TN-C-S system three phase

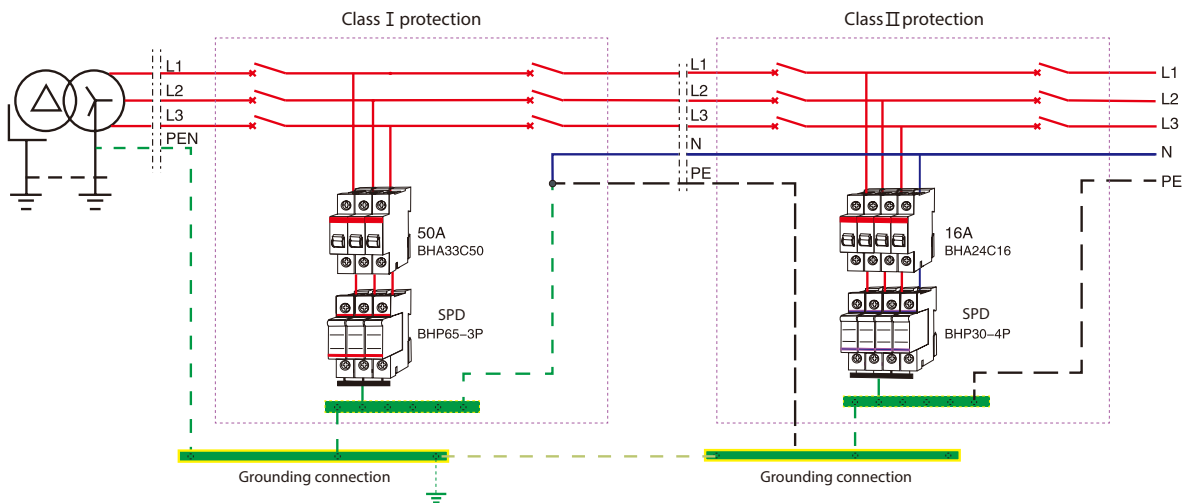

IT system three phase

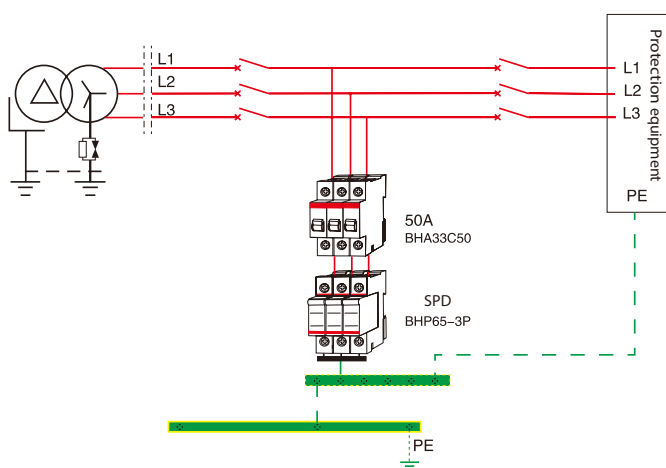

Single-Phase Power Supply Scheme

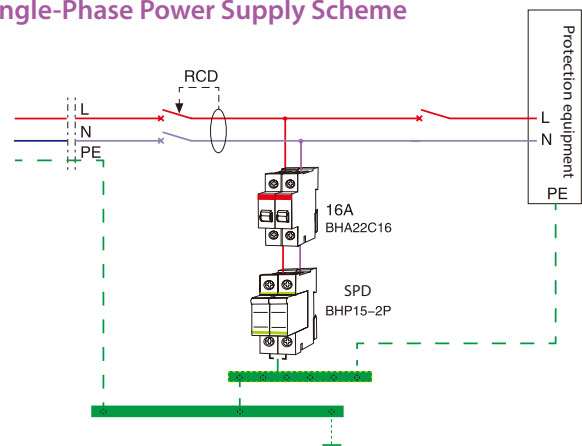

Special notes:

Time-delay leakage protector shall be selected for the RCD in the power supply system; leakage protector insensitive to atmospheric over-voltage shall be selected for the RCD installed in residences and office buildings.

TT System Scheme 1

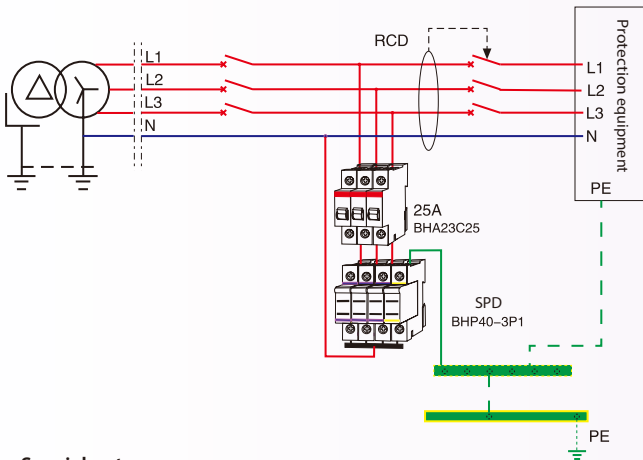

TT System Scheme 2

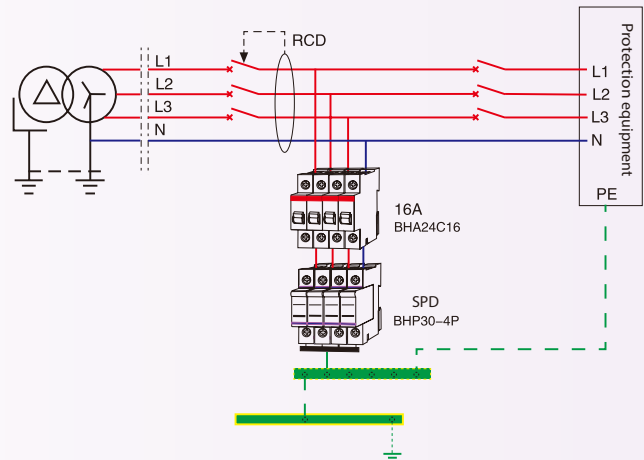

Special notes:

Time-delay leakage protector shall be selected for the RCD in the power supply system; leakage protector insensitive to atmospheric over-voltage shall be selected for the RCD installed in residences and office buildings.

TN-C

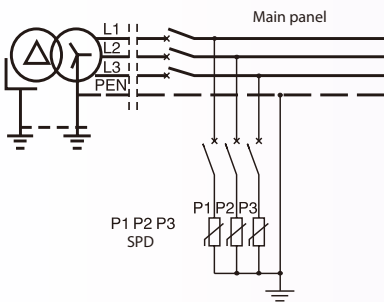

TN-S

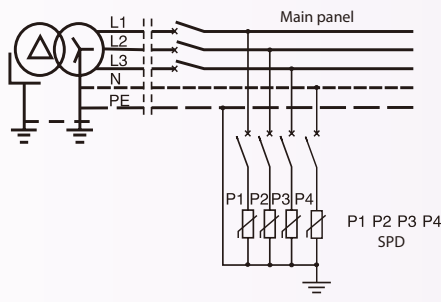

IT

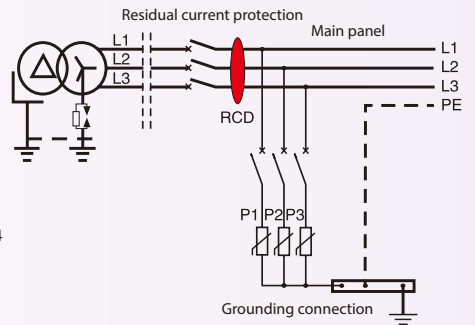

TT System Scheme 1

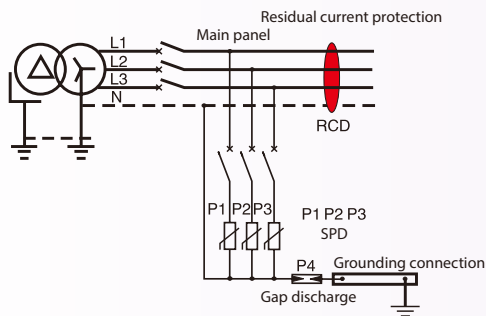

TT System Scheme 2

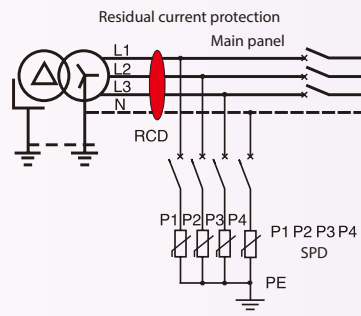

SHIHLIN ELECTRIC & ENGINEERING

MOTOR CONTROL (CONTACTOR/ MS/ MMS), CIRCUIT BREAKER (MCCB/ ELCB/ EMCCB/ MCB), AIR CIRCUIT BREAKER, AUTOMATIC TRANSFER SWITCHES (Panel Board Type/ Residential Unit Use), SURGE PROTECTIVE DEVICE, LOW VOLTAGE POWER CAPACITORS, SMART METER, INVERTER



Breaker & switchgears overseas sales dept.

3F, No.9, Sec. 1, Chang-an E. Rd., Zhongshan Dist., Taipei City 10441, Taiwan

T. +886-2-2541-9822 F. +886-2-2581-2665

e-mail. b.export@seec.com.tw

<http://circuit-breaker.seec.com.tw>

Headquarters

16F, No.88, Sec. 6, Zhongshan N. Rd., Shilin Dist., Taipei City 11155, Taiwan

T. +886-2-2834-2662 F. +886-2-2836-6187

<http://www.seec.com.tw>

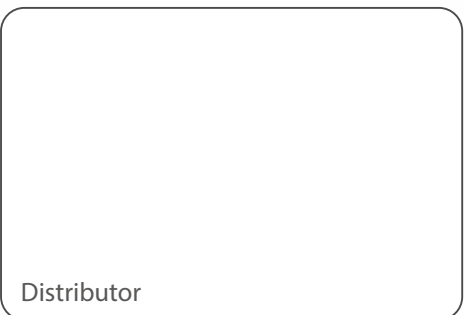

Distributor

B260420E.SPD-OB